



Technical Manual  
**TRANSDUCER AMPLIFIER  
TYPE S7MZ (OPTION Z)**

**Doc. Ref CD1225M**

This manual applies to units of mod status 8 ONWARDS



Affirmed by Declaration  
of Conformity

**USA & Canada**  
**RDP Electrosense Inc.**

2216 Pottstown Pike  
Pottstown, PA 19465  
U.S.A.

Tel (610) 469-0850  
Fax (610) 469-0852  
E-mail [info@rdpe.com](mailto:info@rdpe.com)  
[www.rdpe.com](http://www.rdpe.com)

**All other countries**  
**RDP Electronics Ltd**

Grove Street, Heath Town,  
Wolverhampton, WV10 0PY  
United Kingdom

Tel: +44 (0) 1902 457512  
Fax: +44 (0) 1902 452000  
E-mail: [sales@rdpe.com](mailto:sales@rdpe.com)  
[www.rdpe.com](http://www.rdpe.com)

# INDEX

|      |   |    |
|------|---|----|
| 1.   | INTRODUCTION  | 4  |
| 1.1  | IMPORTANT SAFETY TEST INFORMATION.....  | 4  |
| 1.2  | Declaration of Conformity.....  | 6  |
| 2.   | CONNECTIONS   | 8  |
| 2.1. | Supply.....   | 8  |
| 2.2  | Input & Output Connections.....   | 8  |
| 2.3  | EMC Compliance.....   | 8  |
| 2.4  | Connections for LVDT displacement Transducer.....                             | 9  |
| 2.5  | Connections for Half bridge (differential Inductance) transducer.....         | 9  |
| 2.6  | Connections for Typical Full Bridge Strain Gauge Transducer.....              | 9  |
| 2.7  | Connections for 1/4 and 1/2 Bridge Strain Gauge transducers.....              | 10 |
| 3.   | CONTROLS  | 11 |
| 3.1  | Coarse/Fine Gain (Coarse gain switches and fine gain pot).....                | 11 |
| 3.2  | Zero (Coarse zero switch and fine zero pot).....                              | 11 |
| 3.3  | Input Switch.....   | 12 |
| 3.4  | Over-Range (O/R) LED.....   | 12 |
| 3.5  | Output Jumper Link.....   | 13 |
| 3.6  | CAL (calibration check) Switch.....   | 13 |
| 3.7  | BAL (Balance) potentiometer.....  | 13 |
| 3.8  | SH-CAL. (Remote Shunt Calibration) facility.....                              | 13 |
| 3.9  | Balance Capacitor (Ref. C6).....  | 13 |
| 3.10 | Shunt Calibration Facility.....   | 13 |
| 3.11 | A Calibration Check.....  | 13 |
| 4.   | SETTING-UP PROCEDURES   | 14 |
| 4.1  | Voltage Output - LVDT & Half bridge (differential inductance) Transducer..... | 14 |
| 4.2  | 4-20mA Output - LVDT & Half bridge (differential inductance) Transducer.....  | 14 |
| 4.3  | Voltage output - Strain Gauge transducers - Prime calibration.....            | 15 |
| 4.4  | Voltage output - Strain Gauge transducers - Shunt Calibration.....            | 16 |
| 5.   | LIMITS OPTION T   | 17 |
| 5.1  | Setting the Limits Level (see also section 5.4).....                          | 17 |
| 5.2  | Connections.....  | 17 |
| 5.3  | Controls (for location, refer to Fig.1).....                                  | 17 |
| 5.4  | Limits Operation with 4-20mA Output.....                                      | 18 |
| 5.5  | Limits Option Specification.....  | 19 |
| 6.   | OPTION E MAX/MIN STORE  | 19 |
| 6.1  | Connections.....  | 19 |
| 6.2  | Specification.....  | 19 |
| 7.   | SPECIFICATION (GENERAL)   | 20 |
| 8    | APPLICATION NOTES & APPENDICES  | 22 |
| 8.1  | App. Note 1. Cable types.....   | 22 |
| 8.2  | App. Note 2 Electrical Interference Problems.....                             | 22 |
| 9    | WARRANTY & SERVICE  | 24 |

## TABLE OF FIGURES

|          |   |    |
|----------|---|----|
| Fig.1    | Connector & Control Locations.....                            | 7  |
| Fig.2(a) | Examples of connections to various types of transducers ..... | 9  |
| Fig.2(b) | Signal Cable Installation for Optimum EMC .....               | 10 |
| Fig.3    | Limits Option control Locations .....                         | 18 |

# 1. INTRODUCTION

This manual is only appropriate for the S7M with option Z. If the unit has option Z fitted, this will be identified on the serial number plate.

The S7MZ is a high gain version of the S7M and is an a.c. powered oscillator/demodulator signal conditioning unit for use with load cells or similar quarter-, half- or full-bridge resistive transducers and inductive devices with a very low output.

A high stability oscillator provides sinusoidal excitation and a synchronous demodulator provides high level voltage or current outputs.

Further options include T (dual limits) or E (max/min store) which may also be used with Option Z, but T and E cannot be used together.

Other features include:-

- (a) Aluminium case sealed to IP65.
- (b) Screw terminal connections.
- (c) Simple controls for gain and zero adjustment.
- (d) Input zero and circuit test switch.
- (e) Signal overload indicator.
- (f) 115/230V supply selector switch.
- (g) Calibration: a "CAL" switch is included which connects a precision (59k) resistor across one arm of the bridge. The "SH.CAL" terminal may be used to operate this facility remotely via the internal relay.
- (h) Single jumper link selection of voltage or current output mode.

## 1.1 IMPORTANT SAFETY TEST INFORMATION.

### **READ AND UNDERSTAND THIS MANUAL BEFORE USING THE INSTRUMENT**

#### **ELECTRICAL SAFETY CHECKS**

This instrument was checked for electrical safety, using a portable appliance test instrument, prior to despatch.

If the user wishes to carry out his own tests, the following points must be followed:

- (1) This Safety Class 1 apparatus has a low (<3A) fuse rating and a low current rated power connection cable.
- (2) It is recommended that when carrying out an earth bond test, a test current of 25A should not be applied for more than **six seconds**.
- (3) In general it is **not** recommended that high voltage (e.g. 1.5kV) insulation tests are carried out. This could cause damage to suppressor components.

## **INSTALLATION**

The module may be orientated in any direction but preferably with the glands facing away from any splashing, etc. Resistance to humidity is consistent with the IP rating.

The supply voltage is normally set to 230v unless specified otherwise by the user. If this is changed from that indicated on the label then the label must be changed accordingly.

The unit should be protected from the effects of excessive shock and/or vibration.

**1.2 Declaration of Conformity.**

## **DECLARATION OF CONFORMITY**

**RDP ELECTRONICS LTD.  
Grove Street Heath Town  
Wolverhampton West Midlands  
WV10 0PY  
United Kingdom**

**We declare that the product described in this technical manual is manufactured by RDP Electronics Limited and performs in conformity to the following:**

**The Electromagnetic Compatibility Directive 2014/30/EU**

**The Low Voltage Safety Directive 2014/35/EU**

**The RoHS Directive 2011/65/EU**

**EMC Regulations SI2016/1091**

**Electrical Equipment (Safety) Regulations SI2016/1101**

**Restriction of Hazardous Substances Regulations SI2012/3032**

**R D Garbett  
Director  
RDP Electronics Limited**

Fig.1 Connector & Control Locations

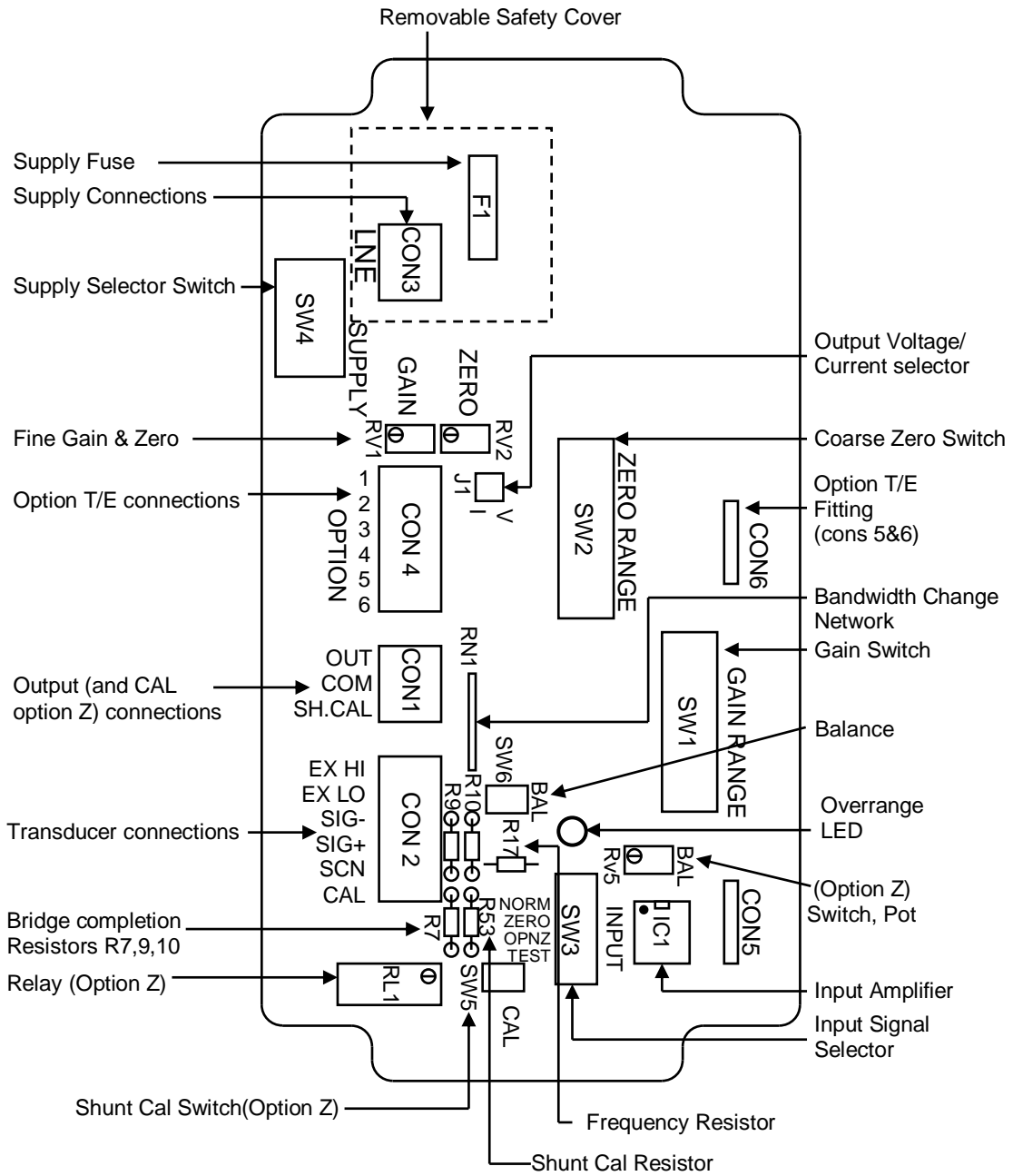

**Note** For mod 12 instruments onwards the frequency resistor is not fitted, different excitation frequencies are available but must be specified at the time of order.

## 2. CONNECTIONS

### 2.1. Supply

#### ALWAYS ISOLATE BEFORE ALTERING CONNECTIONS

Check that the voltage on the label near the inlet gland is correct for application. To change the voltage, operate the slide switch so that it indicates 115 or 230 volts to suit the supply. For supplies less than 100v, change solder link SP1 (near the fuse) to B-C).

The supply terminal block is revealed on removing the internal clip-on cover (squeeze the tips of the plastic studs to release). The supply lead is fed through the largest of the three glands and is connected as shown below:

|   |              |              |                         |
|---|--------------|--------------|-------------------------|
| L | Live         | 115/230v a.c | brown (black US)        |
| N | Neutral      | 0v           | blue (white US)         |
| E | Earth/ground |              | green/yellow (green US) |

All metal case parts are connected to the E terminal.

### 2.2 Input & Output Connections

For details of input and output connections, refer to Fig.1 and Fig.2. To utilise the central gland for both output and option connections, use a multi-core shielded cable such as Farnell 6-core 1A No. 715-244, or RS 9-core 0.25A No. 367-381, or one of the various shielded data cables readily available.

### 2.3 EMC Compliance

- 2.31 For EMC compliance only shielded multi-core cables should be used for the signal input and output connections to this instrument.
- 2.32 The shields of the two cables may be connected to the SCN and common terminals of the transducer connector and output connector, but, for optimum EMC, the cable shield should be terminated as shown in Fig.2(b).
- 2.33 ESD precautions should be used when working on the instrument with the lid removed. The user should ensure he is "earthed" by use of an earthed wrist strap or at least touching earth before touching any component, including wires, terminals or switches.
- 2.34 Segregate signal/supply/output cables.
- 2.35 The transducer body should be earthed. Some transducers such as LVDTs, load cells, etc without an internal case-to-cable shield connection will require a separate connection. This should be to the instrument cable shield or as near (electrically) as possible to this point.
- 2.36 The supply cable green/yellow wire provides a safety ground but for optimum EMC it is desirable to bolt the case via the holes provided to a substantial grounded base.



Fig.2(a) Examples of connections to various types of transducers

Refer to connection diagram supplied with the transducer.

**2.4 Connections for LVDT displacement Transducer**

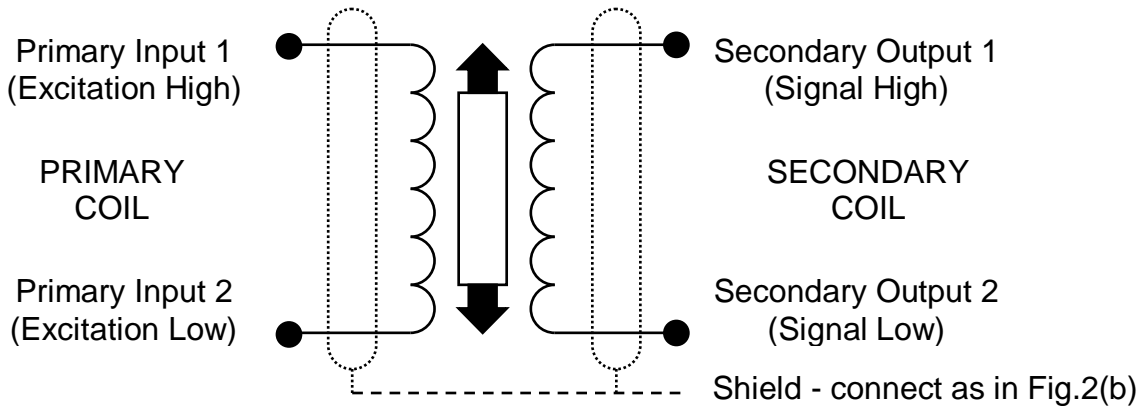

**2.5 Connections for Half bridge (differential Inductance) transducer**

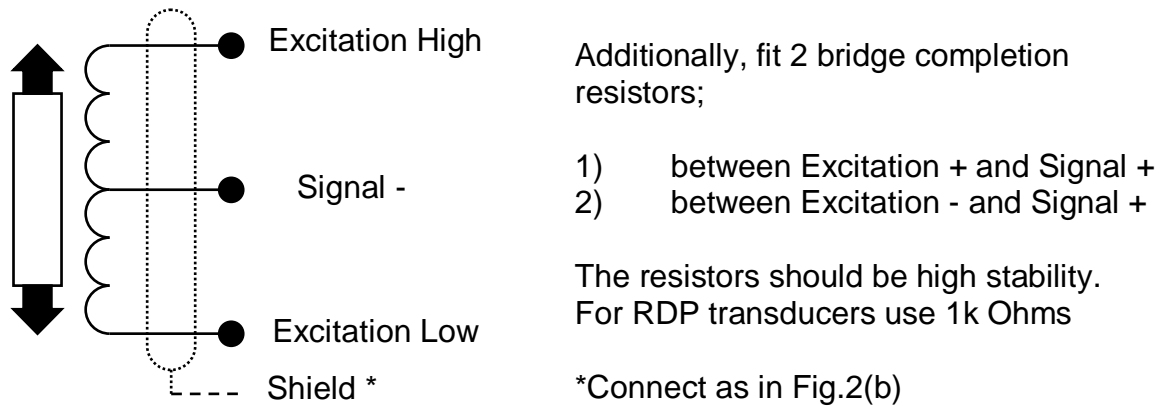

**2.6 Connections for Typical Full Bridge Strain Gauge Transducer**

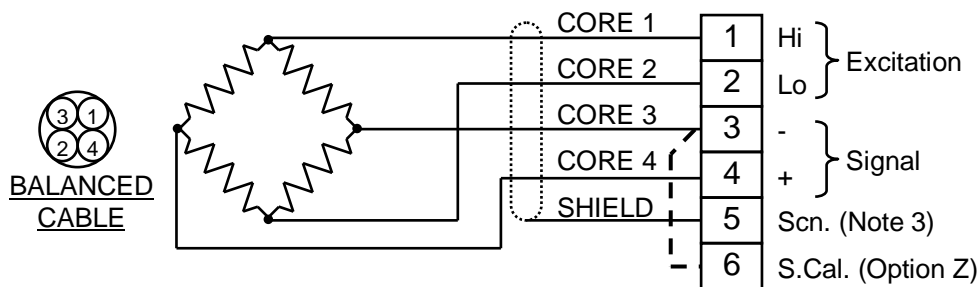

To use Shunt Calibration, connect 'Sig.-' to 'S.cal'. (See 3.6)

- Note 1 Reversing the signal connections reverses the output voltage polarity.
- Note 2 The signal inputs normally have a path to 0V/common via bridge resistors. With floating inputs, this path must be provided, e.g. by linking signal +/- to shield (0V).
- Note 3 Connect SHIELD as shown in fig. 2b

## 2.7 Connections for 1/4 and 1/2 Bridge Strain Gauge transducers

1/4  
Bridge

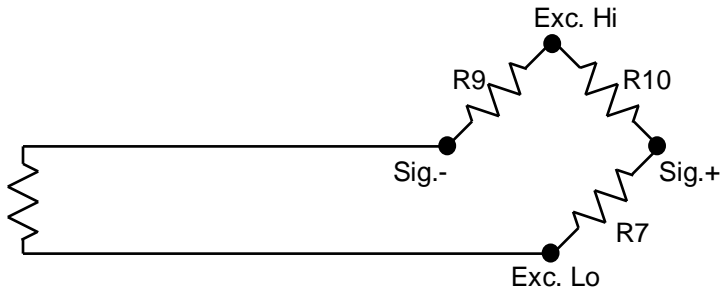

1 Active Gauge.

Resistors may be fitted either on PCB (see Fig. 1 for locations) or into the transducer screw terminals, (CON 2)

1/2  
Bridge

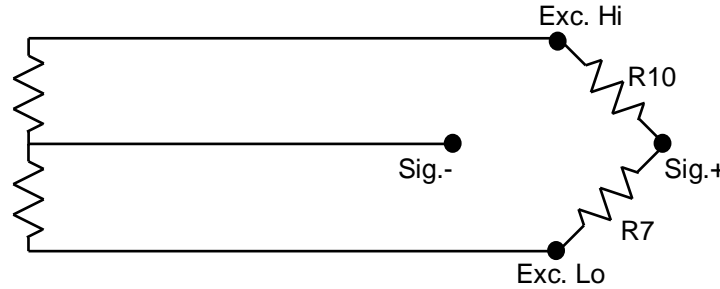

2 Active Gauges.

Resistors may be fitted either on PCB (see Fig. 1 for locations) or into the transducer screw terminals, (CON 2)

Fig.2(b) Signal Cable Installation for Optimum EMC

1

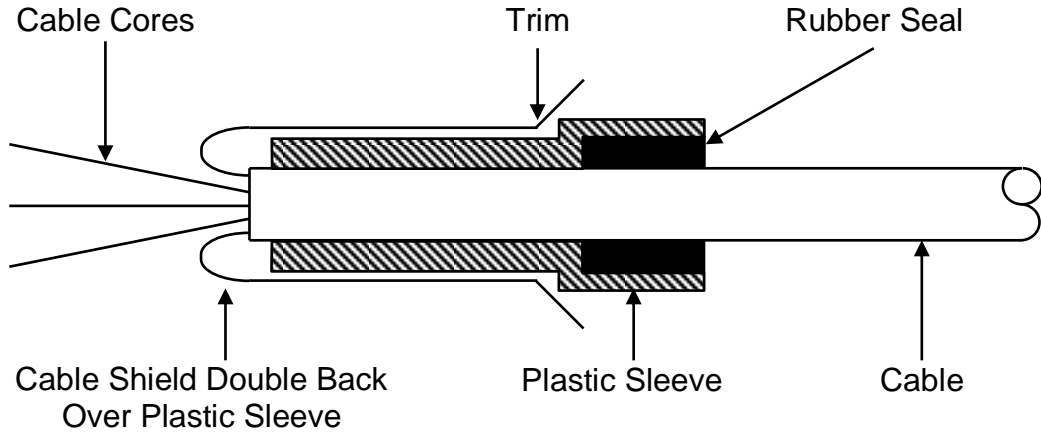

2 Insert the end of the cable, plus the plastic sleeve into the metal outer shell of the gland. The bore of the gland is a tight fit onto the cable shield, giving the required ground contact.

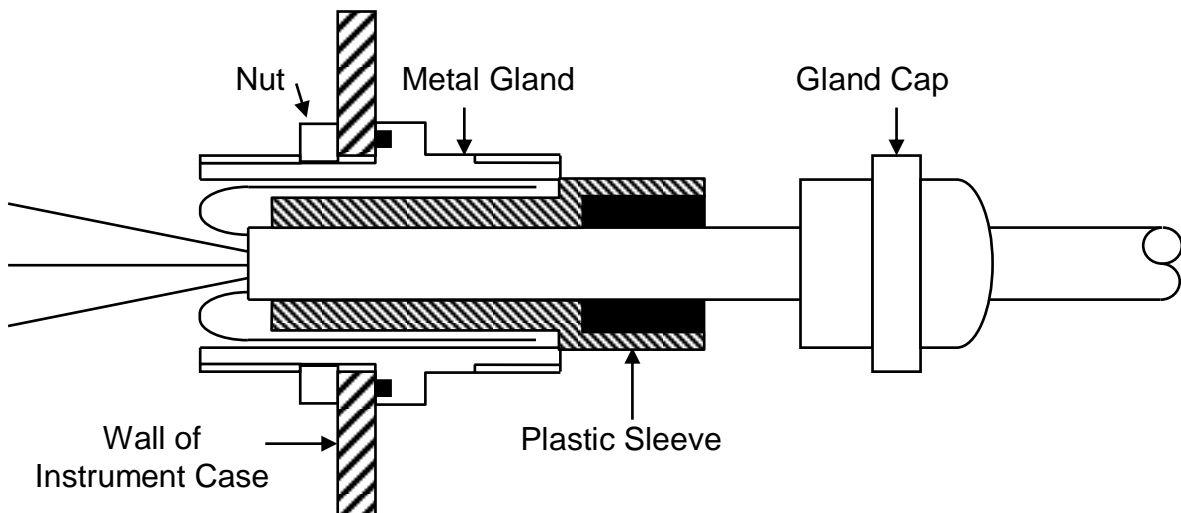

3 Fit gland cap and tighten

### 3. CONTROLS

The standard controls are described below; while controls fitted to option cards are described in the respective sections. The location of controls is shown in Fig.1.

#### 3.1 Coarse/Fine Gain (Coarse gain switches and fine gain pot)

Two controls, coarse and fine, allow an infinite adjustment of gain from x5 to x7000, providing a  $\pm 10\text{v}$  dc output for signals of 1.5mV rms upwards.

Typically, transducer manufacturers' data sheets or calibration certificates will give a figure allowing the full-scale output to be calculated

The following table shows the band of transducer full-scale output voltages appropriate to each of the 10 Gain Range Settings

**Coarse:** The nominal gain is set by either a 10 position slide switch (up to mod 12) or a DIL slide switch (mod 12 onwards). This allows a continuous gain variation covering a wide range of transducer signal as shown below.

| Input Signal Range<br>millivolts - r.m.s. | Gain Switch position<br>up to Mod 12 |            | Toggles ON<br>Mod 12 onwards |            |
|---|--------------------------------------|------------|------------------------------|------------|
|   | V ( $\pm 10\text{v}$ )               | I (4-20mA) | V ( $\pm 10\text{v}$ )       | I (4-20mA) |
| 600 max                                   | 1                                    | -          | 1                            | -          |
| 500-600 max                               | 2                                    | 1          | 1 + 2                        | 1          |
| 240-550                                   | 3                                    | 2          | 1 + 3                        | 1 + 2      |
| 110-300                                   | 4                                    | 3          | 1 + 4                        | 1 + 3      |
| 55-130                                    | 5                                    | 4          | 1 + 5                        | 1 + 4      |
| 30-65                                     | 6                                    | 5          | None                         | 1 + 5      |
| 15-35                                     | 7                                    | 6          | 2                            | None       |
| 7-16                                      | 8                                    | 7          | 3                            | 2          |
| 3-7                                       | 9                                    | 8          | 4                            | 3          |
| 1.5-3.5                                   | 10                                   | 9          | 5                            | 4          |

**Fine:** A screwdriver-adjusted 20-turn potentiometer providing a 2:1 adjustment of gain, interpolating between the coarse gain ranges.

#### 3.2 Zero (Coarse zero switch and fine zero pot)

Two controls, coarse and fine, are used to set the initial output voltage to zero or provide zero suppression, etc.

**Coarse (up to mod 12):** a 10-position slide switch providing a shift in output voltage of  $\pm 10\text{v}$  in 2.5v\* steps (position 10 not used). Position 5 is normal, with 6-9 increasing the output in the positive direction and 4-1 in the negative direction is as shown:

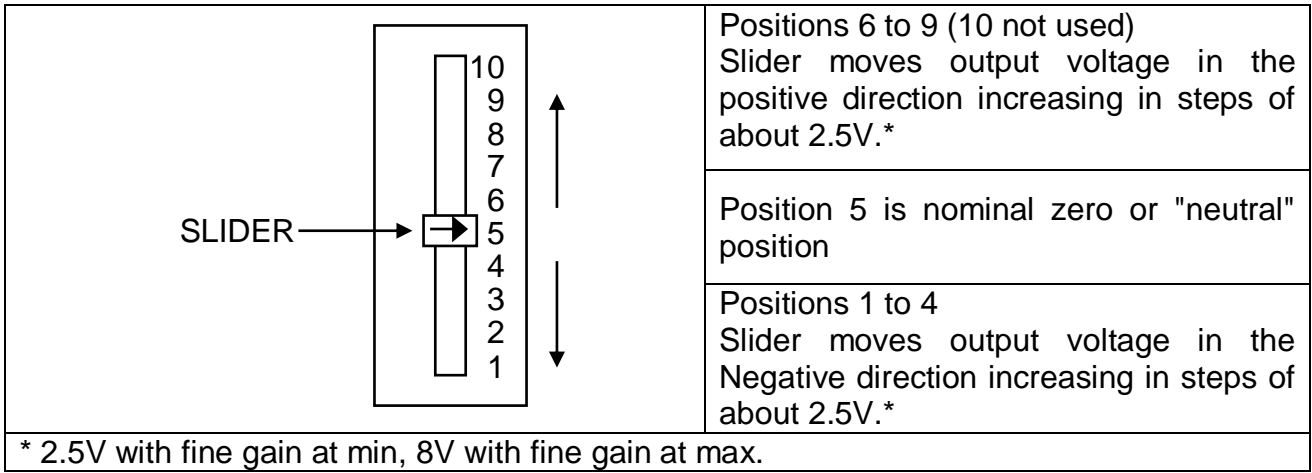

**Coarse (mod 12 onwards):** This is a 6-way DIL switch used to inject different amounts of zero suppression of the output signal, e.g. to obtain a unipolar output signal from a bipolar LVDT. The amplitude and polarity of the output shift provided by the various settings are shown below. Note these will vary according to the Fine Gain setting.

| Toggles ON | Approximate Output Shift in Volts |
|------------|-----------------------------------|
| 2 + 5      | +10.0                             |
| 2 + 4      | +7.5                              |
| 2 + 3      | +5.0                              |
| 2          | +2.5                              |
| NONE       | 0                                 |
| 1          | -2.5                              |
| 1 + 3      | -5.0                              |
| 1 + 4      | -7.5                              |
| 1 + 5      | -10.0                             |

**Fine:** a 20-turn screwdriver-adjusted potentiometer used in conjunction with coarse zero, providing adjustment of output to any value in the range  $\pm 10v$ .

### 3.3 Input Switch

A 4-position slide switch that provides the following functions:

| Switch Posn | Function  |
|-------------|---|
| 1/NORM      | For LVDT and other transducers not requiring input Option Z.                            |
| 2/ZERO      | Connects the amplifier input to 0V/common to allow zero output to be set (zero finder). |
| 3/OPNZ      | Option Z – for use when input Option Z is fitted.                                       |
| 4/TEST      | Inoperative for Option Z.   |

### 3.4 Over-Range (O/R) LED

A red LED indicating when the demodulator input signal exceeds the linear range. This may indicate a lower GAIN RANGE setting is required.

### **3.5 Output Jumper Link**

A 2-position jumper link which, when set to V, selects voltage ( $\pm 10\text{v}$ ) output mode or, when set to I, selects current (4-20mA) output mode.

### **3.6 CAL (calibration check) Switch (See also 2.6 for wire link connection)**

A push-button switch which, while pressed, connects a precision (59k ohm) resistor between the Cal. terminal and excitation low terminal. The Cal. may be linked to Input Lo terminal, or (for best accuracy) at the transducer, so that when CAL is operated the 59k shunts one arm of the bridge. Refer to Section 3.08 (SH-CAL) and 3.10 (Shunt Calibration).

Note that if the reading is not at zero when the CAL switch is operated, the true CAL CHECK figure is the CAL reading less the initial reading.

### **3.7 BAL (Balance) potentiometer**

A 20-turn, screwdriver-adjusted potentiometer which may be used to balance out excessive input signals due to pick-up (stray capacitance, etc.) in long cables. Requires BAL push-button switch pressing to operate correctly.

### **3.8 SH-CAL. (Remote Shunt Calibration) facility**

An internal relay may be operated by a remote switch, relay, etc. to replicate the function of the CAL switch. (3.06). This is achieved by connecting the SH-CAL terminal to COM (0v).

### **3.9 Balance Capacitor (Ref. C6)**

This capacitor (C6) is used in conjunction with the BAL control to compensate for quadrature signals induced in long cable. The value normally fitted should suffice for most cases, e.g. balanced cables of up to 100m or longer.

Unbalanced cables may require a larger value of C6, e.g. 3 or 4 hundred pF. To facilitate changing, the capacitor is mounted on pins.

### **3.10 Shunt Calibration Facility**

This is applicable to resistance bridge transducers only. The method involves switching a precision reference resistor (usually 59k) across one arm of the bridge to produce a precise known output voltage.

The Shunt Calibration Facility can be used as...

### **3.11 A Calibration Check.**

When the prime calibration has been made by applying a precise known pressure or load to the transducer the CAL switch can be operated (normally with zero pressure or load applied) and the reading recorded as the Calibration Check figure. A quick check can be made at any time by comparing new CAL readings with the original.

## **4. SETTING-UP PROCEDURES**

### **4.1 Voltage Output - LVDT & Half bridge (differential inductance) Transducer**

- 4.1.1** Determine the transducer output from the manufacturer's data and set the coarse gain control. Refer also to Section 3.1
- 4.1.2** Connect the transducer to the 6-way connector as detailed in Figure 2a. Switch ON power and allow a 20-minute warm-up period (for maximum accuracy).
- 4.1.3** Set the INPUT Switch to ZERO and adjust the ZERO controls for zero output.
- 4.1.4** Set the INPUT switch to NORM (normal). Adjust the transducer armature until the output is zero volts (measured with a voltmeter). (The FINE ZERO control may be used to obtain an absolute zero indication if the armature adjustment is too coarse.) This determines the transducer centre-stroke position.

Now proceed with either 4.1.5 or 4.1.6 according to application.

#### **4.1.5 Bipolar Operation, e.g. $\pm 5\text{mm}$ gives $\pm 10\text{v}$ output.**

- (a) Move the transducer armature by a precise amount, usually the full scale.(e.g. 5mm (0.200 inches) for  $\pm 5\text{mm}$  ( $\pm 0.2''$ ) transducer) and adjust the FINE GAIN control for the desired output, e.g. 10v. If the output polarity is wrong, reverse the signal wires (blue/green).
- (b) Relocate the transducer armature at the centre of the stroke and check that the OUTPUT is zero, re-adjust the FINE zero control if necessary. Repeat (a).
- (c) Move the armature 5mm (0.2 inches) the other side of centre-stroke and check for -10v. (a small discrepancy is allowed)

#### **4.1.6 Unipolar Operation, e.g. 0 - 10mm stroke gives 0-10v output.**

In order to obtain a 0 to 10V output for  $\pm$  Full scale on the transducer, first calibrate the transducer for  $\pm 5\text{V}$  for  $\pm$  Full scale as detailed in 4.15

Position the transducer such that the output is 0V. Using the coarse and fine ZERO controls offset the output by +5V. This adds 5v to all positions so that -5V becomes 0V and +5V becomes 10V.

### **4.2 4-20mA Output - LVDT & Half bridge (differential inductance) Transducer**

Full stroke operation, e.g.  $\pm 5\text{mm}$  (10mm) stroke gives 4-20mA output.

- 4.2.1** Determine the transducer output from the manufacturer's data sheet and set the coarse gain as in section 3.01
- 4.2.2** Connect the transducer to the 6-way connector as detailed in figure 2. Change jumper link J1 to position "I". Switch ON power and allow a 20 minute warm-up period (for maximum accuracy).
- 4.2.3** Set the INPUT switch to ZERO and adjust the ZERO controls for 4mA (measured

with an ammeter).

- 4.2.4 Set the INPUT switch to NORM (normal). Adjust the transducer armature until the output is 4mA (measured with a current meter). (The FINE ZERO control may be used to obtain an absolute 4mA indication if the armature adjustment is too coarse.) This determines the transducer centre-stroke position.
- 4.2.5 Move the transducer armature to the positive full scale position e.g. +5mm (+0.2 ") for a  $\pm 5\text{mm}$  ( $\pm 0.2$ " ) transducer and adjust Fine Gain for 12mA output.
- 4.2.6 Move the transducer armature to the centre-stroke position and adjust FINE ZERO for 4mA output if necessary.
- 4.2.7 Repeat 4.25 and 4.26 until consistent results are achieved. (This may take a number of settings due to the interaction of the controls.)
- 4.2.8 Move the transducer armature to the negative full scale position and use the COARSE and FINE ZERO controls to set 4mA output.
- 4.2.9 Move the armature to the positive full scale position and check output is 20mA. Repeat 4.28 and 4.29 if necessary.

### **4.3 Voltage output - Strain Gauge transducers - Prime calibration**

- 4.3.1 Determine the transducer bridge output voltage from the manufacturer's data sheet and adjust the COARSE GAIN as in section 3.01.
- 4.3.2 Connect the transducer to the 6-way connector as shown in Figure 2. Switch ON power and allow a 20-minute warm-up period (for maximum accuracy).
- 4.3.3 Set the INPUT switch to ZERO and adjust the ZERO controls (switch and potentiometer) for zero output voltage.
- 4.3.4 With zero load (pressure, etc.) applied to the transducer, set the INPUT switch to OPNZ. Press the BAL switch. Adjust the BAL potentiometer for minimum output voltage. Release the BAL switch. Adjust Fine Zero for zero output voltage.

(Note: the BAL control is used mainly for cancelling cable capacitance effects and should not require further adjustment unless the cable length is changed. Any further output zero adjustments should be done via the ZERO controls). If balance cannot be achieved or the O/R LED lights before sufficient output can be obtained, consider using (a) balanced cables, or (b) lower frequency, or (c) change C6.

- 4.3.5 Apply a precise load (pressure etc.) to the transducer and adjust FINE GAIN for the desired output voltage. Repeat the FINE ZERO and GAIN adjustments if necessary for consistent results.
- 4.3.6 Perform a Calibration Check, by pressing the CAL button and noting the change in reading.

#### 4.4 Voltage output - Strain Gauge transducers - Shunt Calibration.

The shunt calibration method can be used to accurately calibrate the transducer and electronics without having to apply a known pressure or load to the transducer.

Calculate the shunt calibration figure required from the data given on the transducer Calibration Record Sheet (CRS).

$$\begin{array}{lll} \text{From CRS} & \text{output for 100\%} & = W \text{ mV} \\ & \text{output with shunt} & = Y \text{ mV} \end{array}$$

Therefore reading required in CAL is  $Y/W$  x required full scale reading.

**Note:** If CRS states shunt resistors different from the one fitted (59k ohm is standard: other values to order) then it may still be possible to obtain calibration from:

$$\text{CAL figure calculated} \times (R \text{ shunt}/59k) = \text{new CAL figure}$$

Set the COARSE GAIN switch for the required input sensitivity, refer to section 3.1.

Connect up transducer; apply power to the S7MZ and allow a 20-minute warm-up.

**Note** that the shunt cal. circuit should be connected as shown in Section 2.6.

Ensure no load or pressure applied to the transducer.

Operate the CAL switch and adjust the FINE GAIN control to give the required reading as calculated above.



## 5. LIMITS OPTION T

This is a plug-in module with two separate trip limit circuits. Refer to section 5.5 for details of specification. Each limit may be configured as a high or low (positive- or negative-going) detector with normally open/closed relay outputs.

The relays may be operated in normally energised (fail-safe) or de-energised modes.

Limit status is indicated by two LEDs which are ON when the relay is energised, irrespective of operating mode.

Limit levels are set via multi-turn potentiometers over the range  $\pm 10\text{v}$  and monitored via two test points, L1 and L2.

### 5.1 Setting the Limits Level (see also section 5.4)

The limit levels may be set in two ways:-

- (a) Monitoring the potentiometer levels at test point TP1 (L1) or TP2 (L2) with a voltmeter with respect to common TP3 (0v). The meter impedance should be  $>1\text{M}\Omega$ .
- (b) Adjust the transducer for the required output signal level then adjust the limit potentiometer until the LED changes state.

### 5.2 Connections

| Connections to the limits relays are made via the 6-way terminal block labelled "OPTION" as follows:- | Function | Terminal |
|---|----------|----------|
|   | 1 NO     | 1        |
|   | 1 Common | 2        |
|   | 1 NC     | 3        |
|   | 2 NO     | 4        |
|   | 2 Common | 5        |
|   | 2 NC     | 6        |

### 5.3 Controls (for location, refer to Fig.1)

#### 5.3.1 Polarity Switches (SW1, 2)

These are 2-position slide switches which determine whether the limits are high (positive-going) or low (negative-going). Set in the UP position for high and DOWN for low. Refer also to Table 1.

#### 5.3.2 Relay Mode Switches (SW3, 4)

These two switches, similar to the polarity switches, are used to determine whether the relays are in a normally energised or normally de-energised mode. for normally de-energised, set the switches in the UP position; and for normally energised (e.g. fail-safe mode), set the switches in the DOWN position. Refer also to Table 1 for more details.

Fig.3 Limits Option control Locations

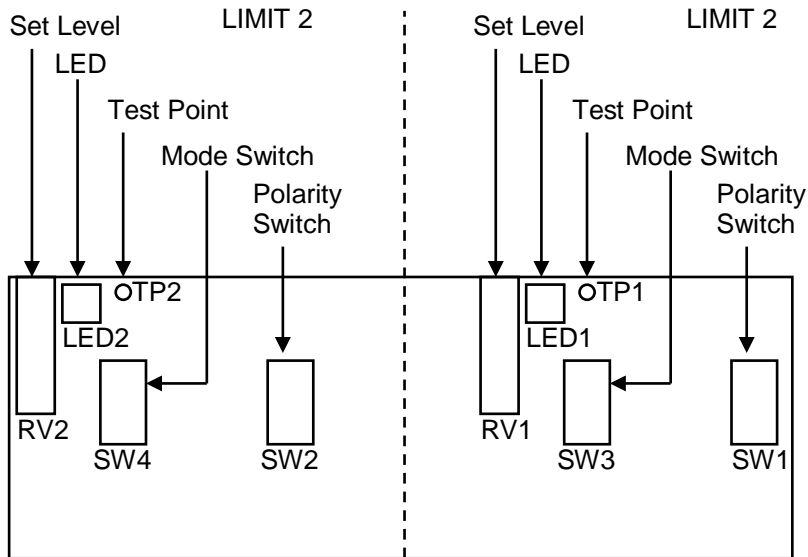

**TABLE 1 RELAY OUTPUT OPERATION**

Note 1: A HIGH limit monitors positive-going signals.  
 A LOW limit monitors negative-going signals  
 < means more negative than: > means more positive than.  
 N means normal (as despatched) settings

| Limit Type | POL. SW 1,2 | MODE SW 3,4 | SIGNAL wrt LIMIT | LED/ RELAY | COMMENTS  |
|------------|-------------|-------------|------------------|------------|-----------|
| 1.HIGH     | UP (N)      | UP (N)      | <<br>>           | OFF<br>ON  |           |
| 2.HIGH     | UP          | DOWN        | <<br>>           | ON<br>OFF  | FAIL SAFE |
| 3.LOW      | DOWN        | UP          | <<br>>           | ON<br>OFF  |           |
| 4.LOW      | DOWN        | DOWN        | <<br>>           | OFF<br>ON  | FAIL SAFE |

Note 2: In fail safe mode the relay is OFF (de-energised) when limit is exceeded or power is removed.

#### 5.4 Limits Operation with 4-20mA Output

When using current (4-20mA) output, the signal to the limits option board is derived from the output of a current-sensing amplifier which acts as a current to voltage converter.

The limit level voltages, as monitored via the L1, L2 test points, are compared to this current-derived signal and should be set with reference to the formula:

Limit level voltage = output current in mA x 0.25 volts.

e.g. for 20mA output, the voltage applied to the limit is 20 x 0.25 = 5v. So, for a limit to operate at 20mA output, set the test point level to 5v.

## 5.5 Limits Option Specification

|                     |  |
|---------------------|--|
| Channels            | 2 independent  |
| Signal Range        | $\pm 10V/\pm 20mA$ (see Section 5.4)                         |
| Accuracy            | $\pm 10mV$ typical (0.05% FS) With signal noise $< 1mV$ .    |
| Response Speed      | 6mS  |
| Tempco              | 0.1mV/°C (0.0005% FS) typical                                |
| Outputs             | Normally open or closed (selectable) 1A, 30V, dc/0.5A, 125ac |
| Hysteresis          | 20mV typical   |
| Expected life cycle | $5 \times 10^6$ operations                                   |

## 6. OPTION E MAX/MIN STORE

This optional circuit board provides a separate output signal which may be selected (via an external wire link) to store either the maximum/ peak or minimum/trough value of the normal output signal (which remains unaffected at the normal output terminal).

The circuit combines high speed and accuracy with zero output droop. Note that MAXIMUM = the most positive value, and MINIMUM = the most negative value of the output signal range.

### 6.1 Connections

| <p>These are made via the 6-way terminal block labelled OPTION as follows:-</p> <p>The stored (peak or trough) output is monitored via terminals 1 and 2. Terminal 2 is internally connected to the normal output common.</p> | Terminal       | Function                   |
|---|----------------|----------------------------|
|   | 1              | Store output ( $\pm 10V$ ) |
|   | 2              | Output common (0V)         |
|   | 3              | +15V output (see text)     |
|   | 4              | Reset input : isolated     |
|   | 5              | Reset common : isolated    |
| 6   | Max/Min select |                            |

The reset input is opto-isolated to improve EMC. To utilise this facility fully, an external supply should be connected between terminals 4 and 5 to reset the output, then disconnected prior to beginning a new measurement. If an external supply is not available, the S7MZ +15v output may be used, which removes the benefits of isolation. Connecting terminal 3 (15v) to 4, and 5 to 2 common (via switch etc.) will reset the output.

With no connection to terminal 6, the unit will operate in peak store mode (determined via an internal pull-up resistor). To operate in trough mode, connect 6 to 2.

### 6.2 Specification

|                |   |
|----------------|---|
| Signal Range   | $\pm 10V$   |
| Accuracy       | $\pm 0.1\%$ FS. ( $\pm 20mV$ plus any signal ripple. See note.)                     |
| Response Speed | 0 – FS (10V) in $\geq 1mS$ for 0.1% accuracy  |
| Reset input    | Opto-isolated 5 to 24V into 2.2k $\Omega$ + diode for $\geq 50ms$ . Isolation 240V. |
| Max/Min Select | Link to unit common (0V) or TTL low (internal 10k $\Omega$ pull-up)                 |
| Output         | $\pm 10V$ at 5mA  |

Note: The Option E board contains an extra active filter circuit to reduce the errors attributable to carrier ripple.

## 7. SPECIFICATION (GENERAL)

Refer also to 5.5 (Limits) and 6.2 (Max/Min)

|                               |   |
|-------------------------------|---|
| Supply                        | 115V or 230V ac (selectable). +10%/-20% 50/60Hz at 2.5VA typical. Refer also to Section 3.1.  |
| Fuse                          | 250mA. T-type 20 x 5mm  |
| Excitation                    | 5V rms at 5kHz 100mA max.<br>(1-10kHz selectable, contact RDP).   |
| Excitation Tempco             | ±0.003%/°C typical  |
| Amplifier Output (selectable) | ±10V at 50mA max. (short-circuit proof), or 4-20mA or 0-20mA into 0 to 600 ohm. This is an active o/p that should not be connected to any external power supply as this will damage unit. |
| Amplifier Gain                | x5 to x7000 in 10 ranges  |
| Input Voltage Range           | 1.5mV to 600mV for 10V output   |
| Linearity                     | ±0.1% of full scale maximum   |
| C.M.R.R.                      | 95dB typical  |
| Shunt Cal. Resistor           | 59k ohm ±0.1% (mounted on pins)   |
| Internal Cal. Operation       | Push-button switch  |
| Remote Cal. Operation         | Relay R-Cal to common (12mA)  |
| Noise                         | 15µV R/T// +3mV R.T.O. typical  |
| Demodulator                   | Synchronous   |
| Zero Tempco                   | ±0.002% F.S./°C typical optimum at ±10V output (0.01% for I mode)   |
| Gain Tempco                   | ±0.004% F.S./°C typical optimum at ±10V output (0.01% for I mode)   |
| Bandwidth                     | Flat to 500Hz (others selectable via plug-in resistor network. Contact RDP)   |
| Output Noise                  | 5mV typical (pk-pk) at 10kHz  |
| Input Impedance               | 10 <sup>9</sup> ohm differential. 10 <sup>9</sup> ohm common mode.  |
| Zero Adjustment Range         | ±10V minimum  |

| EMC Specification                   | When subjected to radiated electromagnetic energy (as EN61000-4-3) an additional error can occur at certain frequencies:  |                       |                              |       |    |      |      |
|-------------------------------------|---|-----------------------|------------------------------|-------|----|------|------|
|                                     | <table> <thead> <tr> <th><u>Field Strength</u></th> <th><u>Typical Maximum Error</u></th> </tr> </thead> <tbody> <tr> <td>10V/m</td> <td>2%</td> </tr> <tr> <td>3V/m</td> <td>0.2%</td> </tr> </tbody> </table> | <u>Field Strength</u> | <u>Typical Maximum Error</u> | 10V/m | 2% | 3V/m | 0.2% |
| <u>Field Strength</u>               | <u>Typical Maximum Error</u>  |                       |                              |       |    |      |      |
| 10V/m                               | 2%  |                       |                              |       |    |      |      |
| 3V/m                                | 0.2%  |                       |                              |       |    |      |      |
| Temperature Range                   | -10 to +50°C  |                       |                              |       |    |      |      |
| Dimensions (excluding cable glands) | 220 x 120 x 81 mm<br>(8.7 x 4.75 x 3.25 inches)   |                       |                              |       |    |      |      |
| Weight                              | 1.8 kg (3.96 lb)  |                       |                              |       |    |      |      |
| Physical Protection                 | IP65 specification  |                       |                              |       |    |      |      |
| Gland Cable Diameter                | 3 to 6.5 mm (0.12 to 0.25 inches) for signals<br>5 to 9 mm (0.2 to 0.35 inches) for supply  |                       |                              |       |    |      |      |

## 8 APPLICATION NOTES & APPENDICES

### 8.1 App. Note 1. Cable types.

When connecting strain gauges or strain gauge transducers to the instrumentation then it is preferable that the cable used is symmetrically balanced. This is particularly important with long cables. For straight lay cables the cores should be chosen so that the cable is balanced as shown in the sketch below

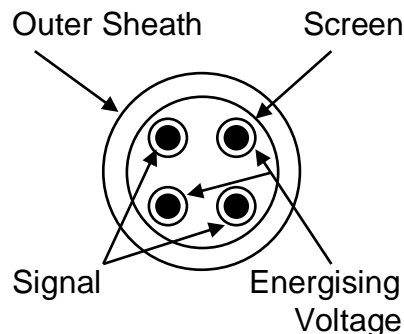

A better alternative is to use a cable made up of two twisted pairs: one pair for the energisation and one for the signal.

Note 1 This is only necessary with very long stroke transducers, or low output transducers, with long cables.

Note 2 When individual strain gauges are used with long cable lengths, it is preferable to mount dummy resistors near the gauge in 1/4 and 1/2 bridge applications

### 8.2 App. Note 2 Electrical Interference Problems

When a Transducer Amplifier is used in an industrial application, some of the following points may be helpful to system engineers to design a trouble-free installation.

In general the operation of electronic instruments and transducers can be affected by electrical interference.

This interference can be generated by the switching of large or reactive loads on the supply causing the production of large voltage spikes and/or variation in the ac mains supply.

Higher frequency interference (radio frequency) is often generated by a large voltage (e.g. back emf from a coil) being switched by a contact. Generally a contact seen to arc whilst switching is producing RF interference. Other sources of RF include portable radios, telephones, etc.

The interference "signals" can enter a transducer measuring system in the following ways:

- a) Direct pick-up by wiring to the instrument. the wiring can be a connection to the transducer supply input or control (e.g. trip relay).
- b) Direct pick-up into the instrument.
- c) Along the mains supply lines.

There are two methods of countering these problems:

- a) suppress the interference generation at source.
- b) Prevent the interference gaining access to the instrumentation circuitry.

Suppression at source is often the best approach. AC coils can often effectively be suppressed by means of connecting, as close to the coil terminals as possible, a 100 ohm resistor in series with 0.1 $\mu$ F across the coil. Proprietary transient voltage clippers - either non-linear resistor or better semiconductor types - are very useful for suppression, mounted across coils and contacts.

Although RDP instruments are fitted with supply suppressors, an exceptionally noisy mains supply can be improved by means of a mains filter unit. These units in their simplest form consist of capacitors and inductors. Mounted at the point where the mains enters the instrument, they can be most effective. A constant voltage transformer is another effective way of cleaning up the mains.

Extra shielding of the transducer, cabling and instrument is a simple, low cost method of preventing particularly directed radiated RF type of interference.

Shielded cable should always be used to connect the transducer to the instrument. Shielded cable is often beneficial for other connections as well. The shield should only be earthed at the instrument end.

It is not good practice to mount the instrument near to contactors, motors, switch transformers, solenoids, etc., but where it is considered necessary to mount the instrument near to such devices, an extra steel enclosure around the instrument would be essential.

In extreme cases, the transducer cable should be run in a steel conduit.

Trip relays fitted inside the Indicator should never be used to switch ac coils. The recommended arrangement is to use a dc slave relay as shown below.

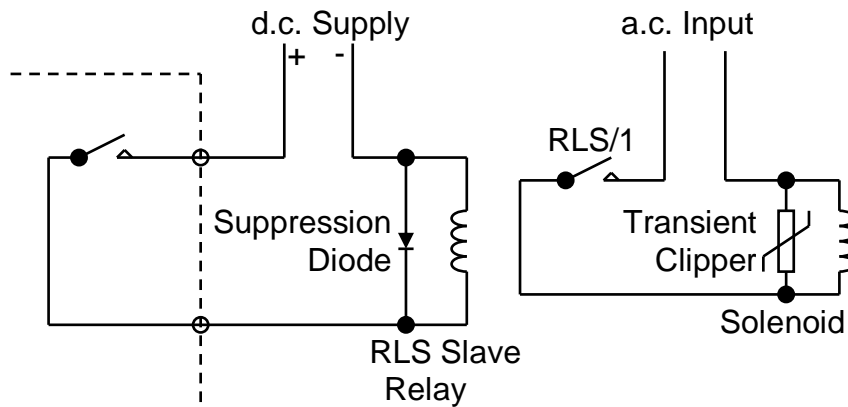

## **9 WARRANTY & SERVICE**

### WARRANTY.

R.D.P. Electronics products are warranted against defects in materials or workmanship. This warranty applies for one year from the date of delivery. We will repair or replace products that prove to be defective during the warranty period provided they are returned to R.D.P. Electronics.

This warranty is in lieu of all other warranties, expressed or implied, including the implied warranty of fitness for a particular purpose to the original purchaser or to any other person. R.D.P. Electronics shall not be liable for consequential damages of any kind.

If the instrument is to be returned to R.D.P. Electronics for repair under warranty, it is essential that the type and serial number be quoted, together with full details of any fault.

### SERVICE.

We maintain comprehensive after-sales facilities and the instrument can, if necessary be returned to our factory for servicing.

Equipment returned to us for servicing, other than under warranty, must be accompanied by an official order as all repairs and investigations are subject to at least the minimum charge prevailing at the date of return.

The type and serial number of the instrument should always be quoted, together with full details of any fault and services required.

### IMPORTANT NOTES.

1. No service work should be undertaken by the customer while the unit is under warranty except with the authorisation of RDP Electronics.
2. If the instrument is to be returned to R.D.P. Electronics for repair, (including repair under warranty) it is essential that it is suitably packed and that carriage is insured and prepaid. R.D.P. Electronics can accept no liability whatsoever for damage sustained during transit.
3. It is regretted that the above warranty only covers repairs carried out at our factory. Should the instrument have been incorporated into other equipment that requires our engineers to perform the repair on site, a charge will be made for the engineer's time to and from the site, plus any expenses incurred

The aforementioned provisions do not extend the original warranty period of any product that has been either repaired or replaced by R.D.P. Electronics.

**THIS WARRANTY MAY BE NULL AND VOID SHOULD  
THE CUSTOMER FAIL TO MEET OUR TERMS OF PAYMENT.**