



Technical Manual
TRANSDUCER AMPLIFIER
TYPE DR7AC

Doc. Ref CD2402Q



Affirmed by Declaration
of Conformity

USA & Canada
RDP Electrosense Inc.

2216 Pottstown Pike
Pottstown, PA 19465
U.S.A.

Tel (610) 469-0850
Fax (610) 469-0852
E-mail info@rdpe.com
www.rdpe.com

All other countries
RDP Electronics Ltd

Grove Street, Heath Town,
Wolverhampton, WV10 0PY
United Kingdom

Tel: +44 (0) 1902 457512
Fax: +44 (0) 1902 452000
E-mail: sales@rdpe.com
www.rdpe.com

INDEX

1.	INTRODUCTION.....	3
1.1	Declaration of Conformity	4
2.	INSTALLATION INSTRUCTIONS	5
2.1	EMC Requirements	5
2.2	Unit Mounting	5
2.3	Connections General.....	6
2.4	Internal Controls	6
2.5	Transducer connections (LVDT and half bridge)	7
3.	CONTROLS	8
3.1	Voltage/Current Output.....	8
3.2	Coarse Gain Selection.....	8
3.3	Fine Gain (On front panel, labelled GAIN).....	8
3.4	Coarse Zero.....	8
3.5	Zero Input.....	9
3.6	Fine Zero (On front panel, labelled ZERO).....	9
3.7	Over-Range Indicator	9
3.8	Excitation Voltage.....	9
3.9	Excitation Frequency	9
3.10	Master/Slave.....	9
4.0	SETTING UP PROCEDURES.....	10
4.1	LVDT & Half Bridge (Differential Inductance) Transducers	10
5.	SPECIFICATION	11
6	WARRANTY AND SERVICE.....	12

TABLE OF FIGURES

Fig. 1	Connections.....	6
Fig. 2	Internal Controls	6
Fig. 3a	LVDT transducer connections.....	7
Fig. 3b	Half bridge (differential inductance) transducer connections.....	7
Fig 4.	Excitation Frequency	9
Fig 5.	Master/Slave Connections.....	9

1. INTRODUCTION

The DR7AC is a single channel signal-conditioning unit for use with transducers requiring AC excitation and synchronous demodulation, producing a DC output voltage or current.

The DR7AC incorporates a DC-DC converter ensuring that the output of the unit is electrically isolated from the supply.

Units may be master-slaved in systems where carrier frequency beating is a problem.

The unit is housed in a DIN-rail mounting thermoplastic case with recessed screw-clamp terminals for all connections and 25-turn front-panel-accessible span and zero adjustments.

All other controls are internal including coarse gain and zero switches, a zero input switch and jumper links for master/slave setting and excitation frequency setting.

The unit is suitable for use with the complete range of RDP LVDT transducers.

DECLARATION OF CONFORMITY

**RDP ELECTRONICS LTD.
Grove Street, Heath Town
Wolverhampton, West Midlands
WV10 0PY
United Kingdom**

We declare that the product described in this technical manual is manufactured by RDP Electronics Limited and performs in conformity to the following:

The Electromagnetic Compatibility Directive 2014/30/EU

RoHS Directive 2011/65/EU

EMC Regulations SI2016/1091

Restriction of Hazardous Substances Regulations SI2012/3032

**R D Garbett
Director
RDP Electronics Limited**

2. INSTALLATION INSTRUCTIONS

2.1 EMC Requirements

For optimum EMC performance use shielded multi-core cables for connection to this instrument; the cable shield may be terminated by means of a short "pig-tail" and connected to the terminals marked:

- (a) Pin 5 – Transducer cable
- (b) Pin 15 – Supply/Output cable

The DIN-rail to which the unit is attached should be earthed.

The screw clamp terminals can accept either solid or stranded wire sizes from 0.2 mm (24 AWG) to 2.5 mm (12 AWG).

NOTES:

1. Cable shields to be grounded at only one end - the DR7AC end, although grounding at both ends may reduce the effects of high frequency EMI.
2. When the DR7AC is a small part of a large electrical installation, ensure the cables to and from the DR7AC are segregated from electrically noisy cables.
3. Ensure cables to and from the DR7AC are routed away from any obviously powerful sources of electrical noise, e.g. electric motor, relays, solenoids.
4. ESD precautions should be used when working on the instrument with the lid removed. The user should ensure he is "grounded" by use of an earthed wrist strap or at least touching earth before touching any component including wires, terminals or switches.
5. The transducer body should be grounded. Some transducers such as LVDTs, load cells, etc. without an internal body-to-shield connection, require a separate earth. This should preferably be connected to the instrument shield terminal or as near (electrically) as possible to this point.

2.2 Unit Mounting

The DR7AC housing is a standard DIN rail enclosure which can clip directly to a 35 mm top hat rail. The units can be mounted side by side if in an ambient temperature up to 40°C. Above this temperature, a gap of 15 mm should be left in between each unit.

2.3 Connections General

Transducer, supply and output connections are made by 4 x 4 way screw-clamp terminals as shown in Fig 1.

To reverse output polarity, reverse signal hi/signal lo. Voltage output is between Volts Out and common, current output is between current out and common. Output common is internally connected to Excitation Lo.

WARNING: INCORRECT SUPPLY CONNECTION, e.g. CONNECTING SUPPLY WIRE TO OUTPUT (O/P) MAY DAMAGE THE UNIT AND INVALIDATE THE WARRANTY.

Fig. 1 Connections



1	Excitation Hi
2	Excitation Lo
3	Signal Lo
4	Signal Hi
5	Screen
6	Master
7	Slave
8	m/s comm
9	Volts Out
10	Common
11	Common
12	Current Out
13	Supply +
14	Supply -
15	Screen
16	N/C

2.4 Internal Controls

To access internal controls the front part of the DR7AC case needs to be removed. To do this, use a small screw driver to gently press in the clips behind terminal 1-4 and 13-16. At the same time pull forward the front of the case. The front of the case and pcb assembly should now slide forward.

It will usually only be necessary to make changes to Gain and Zero controls.

Fig. 2 Internal Controls

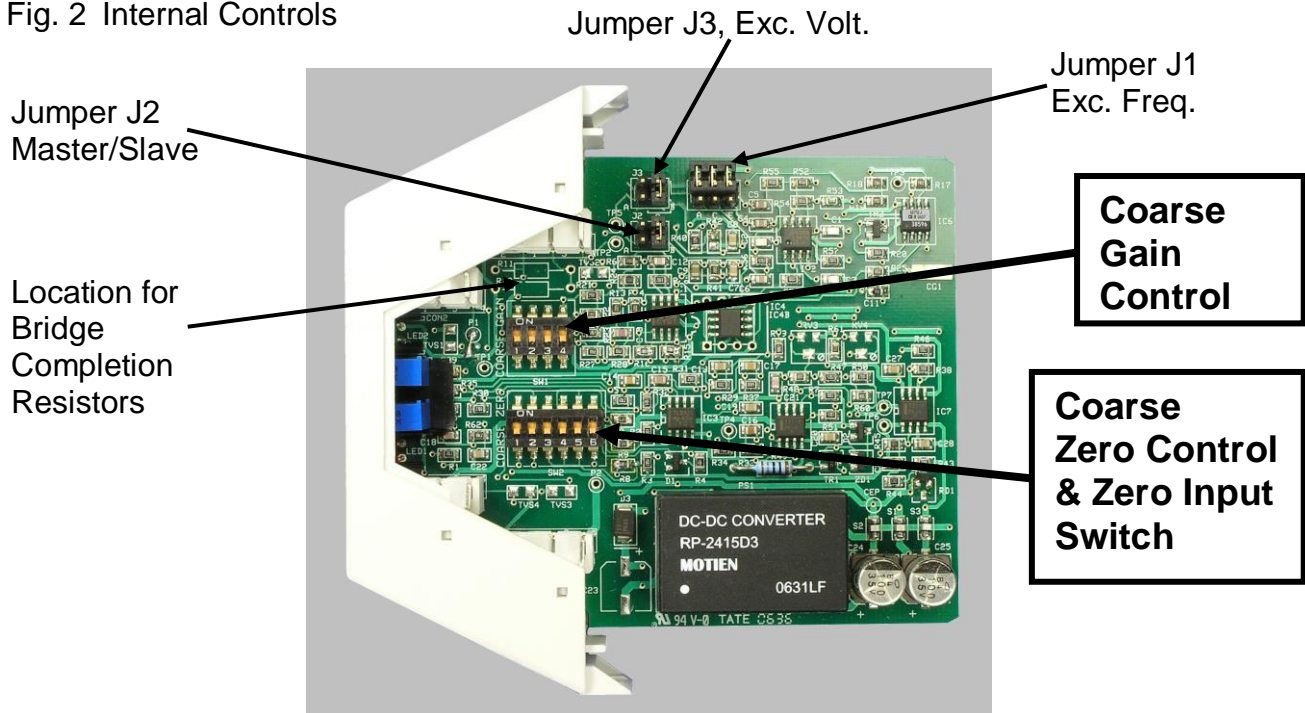

To put case back together, gently slide pcb assembly into case guide slots. Ensure pcb earth pad CG1 is lined up with the earth clip inside the case, and push back until the front of the case clicks back into place.

2.5 Transducer connections (LVDT and half bridge)

Fig. 3a LVDT transducer connections.

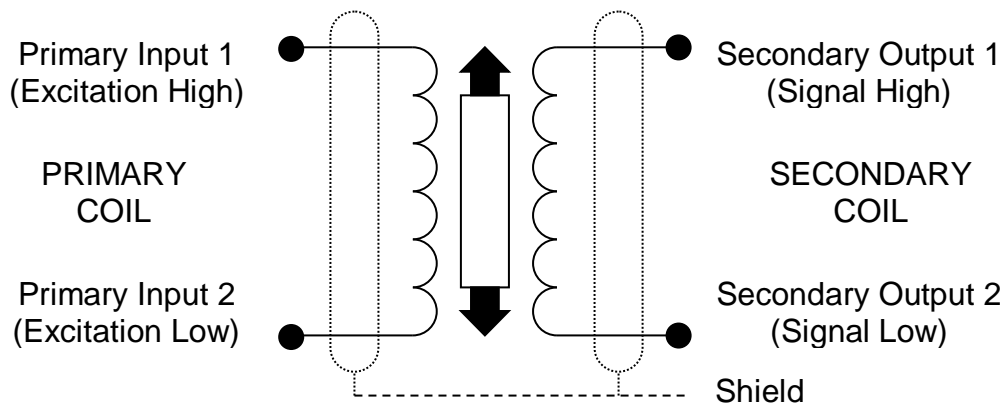

See fig. 1 for pin designations.

Most RDP LVDT transducers also have a BLACK wire. This is not required with the DR7AC amplifier and should be insulated and left unconnected.

If the above configuration does not give the required output phase (i.e. the output *rises* for outward transducer movement instead of *falling*); reverse signal high and signal low connections.

Fig. 3b Half bridge (differential inductance) transducer connections.

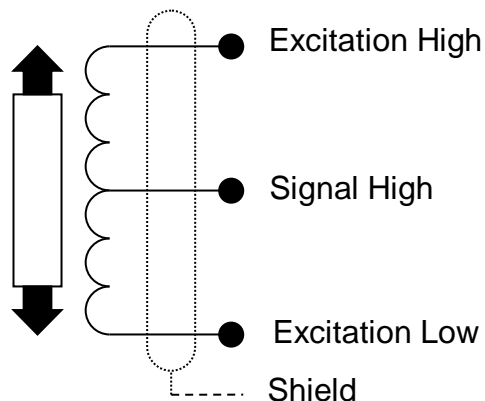

In addition to these connections, it is necessary to add two bridge completion resistors to compensate for the fact that the transducer is only half bridge. For RDP transducers, the resistors should be 1k Ohms, high stability. These should be mounted in R11 and R12 locations, as shown in Fig. 2.

If when connected, the phase of the amplifier output is not as required (for example, an inward moving armature causes a *rising* amplifier output when a *falling* output is required) then reversing the excitation high and excitation low wires will correct this.

3. CONTROLS

(For locations, see Figure 2)

3.1 Voltage/Current Output

Voltage output is available between pins 9 & 10 (common). Current output is available between pins 12 and 11 (common). Pins 10 and 11 are internally connected.

3.2 Coarse Gain Selection

Typically, transducer manufacturers' data sheets or calibration certificates will give a figure allowing the full-scale output to be calculated. Possible formats for this are as follows; **the examples assume a transducer range of ±50mm.**

Sensitivity format	Explanation	To convert to F.S. output
mV/V/mm e.g. 46mV/V/mm	Millivolts of output, per volt of excitation, per mm of travel	Sensitivity x 1 x range in mm e.g. 0.046 x 1 x 50 = 2.3V
V/V at full-scale, e.g. 2.3 V/V	Volt of output, per volt of excitation, at full-scale	Sensitivity x 1 e.g. 2.3 x 1 = 2.3V
mV/mm at a specified excitation voltage. E.g. 230mV/mm at 5V exc.	Millivolts of output, per mm of travel, given a specified excitation voltage.	(Sensitivity / specified excitation voltage) x 1 x range in mm e.g. (0.230/5) x 1 x 50=2.3V
The standard excitation of the DR7AC is 1V, as used in the calculations above.		

The following table shows the band of transducer full-scale output voltages appropriate to each of the 8 Gain Range Settings. For example, a transducer with a full-scale output of 2.3V would be correctly set as gain range 3.

An 4-way toggle switch, SW1, sets the overall gain in the ranges shown below:

SW1 toggles ON	Gain Range	Gain Range (Approximate)	Recommended Input		
			For ±5V O/P	For 4-20mA O/P	For ±10V O/P
1	1	X0.07 to 0.25	4V max	4V max	4V max
1+2	2	0.25 to 0.7	4V max	4V max	4V max
1+3	3	0.7 to 2.5	2-4V max	1.7-4V max	4V max
1+4	4	2 to 6	0.8-2.5	0.7-2	1.6-4V max
NONE	5	5 to 20	0.3-1	0.22-0.8	0.6-2
2	6	17 to 50	0.1-0.3	0.07-0.25	0.2-0.6
3	7	50 to 170	0.03-0.1	0.02-0.08	0.06-0.2
4	8	170 to 500	0.01-0.03	-	0.02-0.06

3.3 Fine Gain (On front panel, labelled GAIN)

A screwdriver-adjusted, 25-turn potentiometer providing a 4:1 adjustment of gain, interpolating between the ranges set by the GAIN RANGE switch.

3.4 Coarse Zero

A 5-way toggle switch, SW2, (toggle 6 – see section 3.5) provides output zero shifts of about 1V per step (with Fine Gain at minimum – up to 4V at maximum). When used with FINE ZERO will suppress any output (up to 5V) to zero. All toggles OFF is normal, ie no suppression applied. Switching toggle 1 ON with toggles 3, 4 or 5 will suppress positive outputs. Switching toggle 2 ON with toggles 3, 4 or 5 will suppress negative outputs. The suppression increases when toggles 3, 4 or 5 are switched ON.

3.5 Zero Input

SW2 toggle 6 which, when switched to ON, zero's the signal, input voltage to the amplifier irrespective of transducer position. This enables a true amplifier zero to be realised.

3.6 Fine Zero (On front panel, labelled ZERO)

A screwdriver-adjusted, 25-turn potentiometer allowing adjustment of output zero by $\pm 1V$ to $\pm 4V$ depending on Fine Gain setting. Used with 3.3 will provide up to 100% suppression.

3.7 Over-Range Indicator

A red lamp that indicates when the demodulator input exceeds the linear range.

3.8 Excitation Voltage

Units are normally supplied with 1V excitation. This can be changed to 3V by changing J3 to B-C.

3.9 Excitation Frequency

Fig 4. Excitation Frequency

If necessary, excitation frequency can be changed by moving J1 as shown.

Figure 2 shows the location of J1.

Other excitation frequencies are available if stated when ordering.

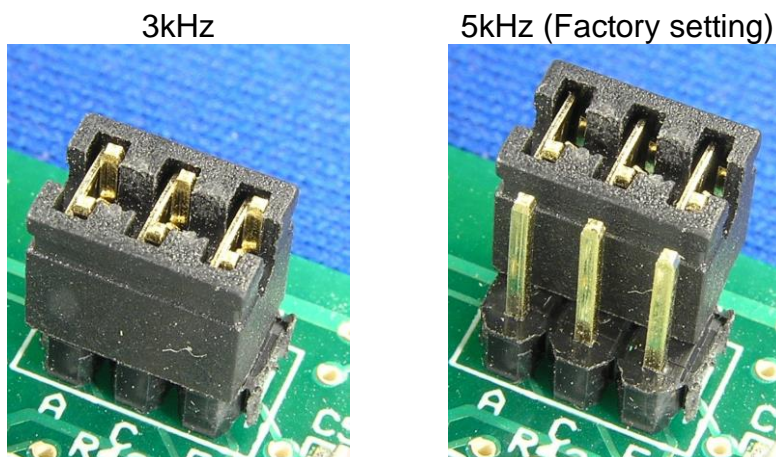

3.10 Master/Slave

The unit may be configured as a master oscillator or slave oscillator by the setting of J2.

For Master oscillator (Factory Default)	link J2	B-C	See Fig 2 for the location of J2
For Slave units	link J2	A-D	

Link terminal 6 on the MASTER unit with terminal 7 on the SLAVES and link terminal 8 on all units as shown below:

Fig 5. Master/Slave Connections

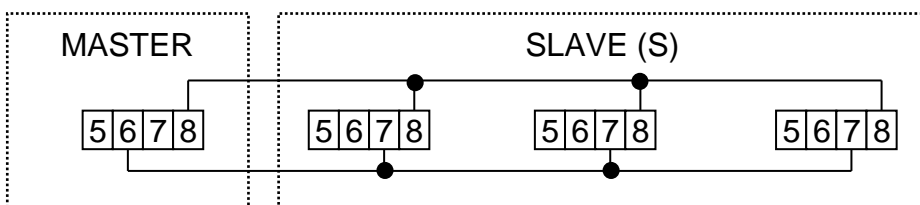

4.0 SETTING UP PROCEDURES

4.1 LVDT & Half Bridge (Differential Inductance) Transducers

4.1.1 Determine the transducer full scale output from the manufacturer's data sheet and set the Coarse Gain control as shown in Sections 3.

4.1.2 Connect the transducer to the 4-way connector as detailed in Section 2. Switch ON power and allow a 15-minute warm-up period (for maximum accuracy).

4.1.3 Switch on the ZERO INPUT switch (SW2 toggle 6) and adjust the ZERO controls on the DR7AC for either 0 volts or 12 mA output (depending on which output is being used). Switch off the ZERO INPUT switch.

4.1.4 Adjust the transducer armature for either 0 volts or 12 mA output from the DR7AC. The FINE ZERO control may be used to obtain an absolute zero indication if the armature adjustment is too coarse.

Now proceed with either 4.1.5 or 4.1.6 according to application.

4.1.5 Bipolar Operation (e.g. $\pm 5V$ or 4-20mA)

(a) Move the transducer armature by a precise amount (e.g. 5mm for a D6/05000 transducer) and adjust the FINE GAIN control for the desired output, e.g. 5V, or 20mA.

(b) Relocate the transducer armature at the centre of the stroke and check that the output is zero. Re-adjust the FINE ZERO control if necessary.

Repeat (a) and (b) for consistent results.

(c) Move the armature to the full-scale position in the opposite direction and check for example -5v or 4mA output.

4.1.6 Unipolar Operation (e.g. 0 to 10V)

If it is required that the transducer be used over its entire working range in the one direction, e.g. 0 to 10mm for a D6/05000 transducer, then the zero controls are used to "back-off" the signal equivalent to 5mm, then:-

(a) Set up as in 4.1.5, i.e. $\pm 5V$ output for $\pm 5mm$ using a D6/05000.

(b) Move the armature by exactly 5mm (for a D6/05000 transducer) and then adjust the ZERO controls to back off this signal to zero. Now move the armature back 10mm and adjust the FINE GAIN control for the required output.

(c) Repeat (b) until consistent results are obtained. If, for any reason, the coarse gain is changed, restart the whole procedure.

5. SPECIFICATION

Supply		9 to 36 V DC 250 mA max (Isolated from output)
Voltage Output		±10V into 2kΩ
Current Output-		4-20mA into 100/550Ω max. Overload internally limited to 30mA max. This is an active output that should not be connected to any external power supply as this will damage unit.
Oscillator Output		1V rms. at 5kHz standard. 25mA maximum. 3Vrms and 3 kHz also available.
Oscillator Temperature Coefficient		0.005%/°c typical
Demodulation		Synchronous
Amplifier Gain		X0.07 to x500 in 8 ranges with fine control interpolation
Zero Range		±5V minimum
Linearity		0.05% of full scale
Input Resistance		130k ohm differential
Zero Stability	Voltage Output Current Output	0.002% of FS typical/°C (optimum at ±10V o/p) 0.005% of FS typical/°C
Gain Stability	Voltage Output Current Output	0.005% of FS typical/°C (optimum at ±10V o/p) 0.01% of FS typical /°C
Bandwidth		DC to 250Hz (flat)
Noise -Voltage Output Current Output		5mV RMS 20µA RMS typical
EMC Specification		When subjected to radiated electro-magnetic energy (as EN61000-4-3) an additional error can occur at certain frequencies:
	Field Strength	Typical Maximum Error
	10V/m	1.5%
	3V/m	0.1%
Temperature Range		-10°C to +60°C
Dimensions		114.5 x 99 x 22.5 mm
Weight		125 g
Seals		IP20 specification

6 WARRANTY AND SERVICE

WARRANTY.

R.D.P. Electronics products are warranted against defects in materials or workmanship. This warranty applies for one year from the date of delivery. We will repair or replace products that prove to be defective during the warranty period provided they are returned to R.D.P. Electronics.

This warranty is in lieu of all other warranties, expressed or implied, including the implied warranty of fitness for a particular purpose to the original purchaser or to any other person. R.D.P. Electronics shall not be liable for consequential damages of any kind.

If the instrument is to be returned to R.D.P. Electronics for repair under warranty, it is essential that the type and serial number be quoted, together with full details of any fault.

SERVICE.

We maintain comprehensive after-sales facilities and the instrument can, if necessary be returned to our factory for servicing.

Equipment returned to us for servicing, other than under warranty, must be accompanied by an official order as all repairs and investigations are subject to at least the minimum charge prevailing at the date of return.

The type and serial number of the instrument should always be quoted, together with full details of any fault and services required.

IMPORTANT NOTES.

1.No service work should be undertaken by the customer while the unit is under warranty except with the authorisation of RDP Electronics.

2.If the instrument is to be returned to R.D.P. Electronics for repair, (including repair under warranty) it is essential that it is suitably packed and that carriage is insured and prepaid. R.D.P. Electronics can accept no liability whatsoever for damage sustained during transit.

3.It is regretted that the above warranty only covers repairs carried out at our factory. Should the instrument have been incorporated into other equipment that requires our engineers to perform the repair on site, a charge will be made for the engineer's time to and from the site, plus any expenses incurred.

The aforementioned provisions do not extend the original warranty period of any product that has been either repaired or replaced by R.D.P. Electronics.

**THIS WARRANTY MAY BE NULL AND VOID SHOULD
THE CUSTOMER FAIL TO MEET OUR TERMS OF PAYMENT.**