

Technical Manual  
**LVDT'S**  
**FITTED WITH E746H IN-LINE MODULES**

Doc. Ref CD2554C



Affirmed by Declaration  
of Conformity

**USA & Canada**  
**RDP Electrosense Inc.**

2216 Pottstown Pike  
Pottstown, PA 19465  
U.S.A.

Tel (610) 469-0850  
Fax (610) 469-0852  
E-mail [info@rdpe.com](mailto:info@rdpe.com)  
[www.rdpe.com](http://www.rdpe.com)

**All other countries**  
**RDP Electronics Ltd**

Grove Street, Heath Town,  
Wolverhampton, WV10 0PY  
United Kingdom

Tel: +44 (0) 1902 457512  
Fax: +44 (0) 1902 452000  
E-mail: [sales@rdpe.com](mailto:sales@rdpe.com)  
[www.rdpe.com](http://www.rdpe.com)

## LVDT'S FITTED WITH E746H IN-LINE MODULES

The E746H in-line module is a simple method of converting an AC LVDT into a DC in –DC out transducer. The E746H contains high quality electronics for energisation and signal conditioning. The E746H has been specifically designed for compatibility with A-D converters and process control systems.

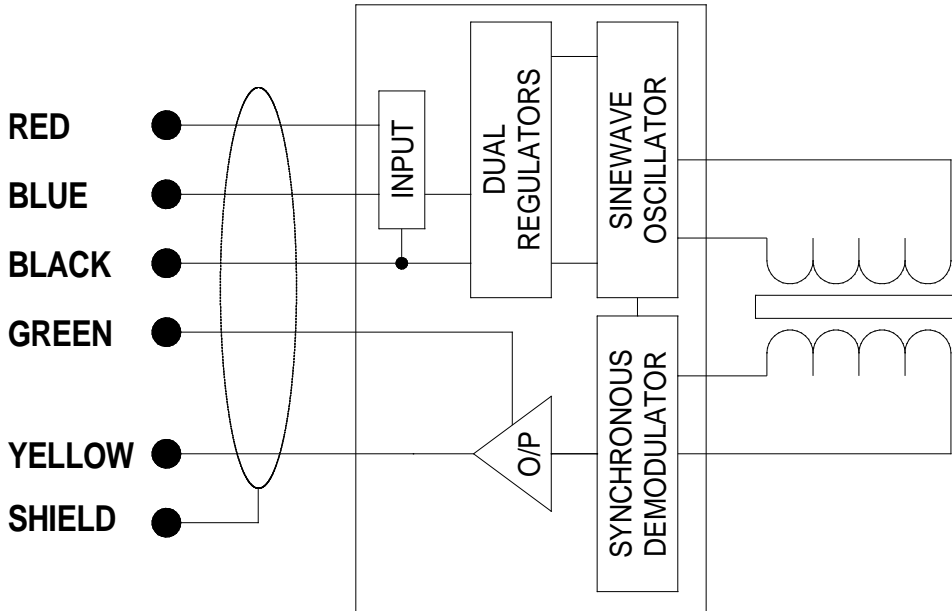

### Connections

SINGLE SUPPLY (Note 1)	CABLE CORE	DUAL SUPPLY
Supply Positive (V+)	RED	Supply Positive (V+)
Supply Common	BLUE	Supply Negative (V-)
Output Common (Note 2)	BLACK	0V Common I/P O/P
Output 2: $\pm 5V$	GREEN	Output 2: $\pm 5V$
Output 1: 0 to 10V	YELLOW	Output 1: 0 to 10V
Ground	Screen (Note 3)	Ground

- Note:
1. Supply must be floating w.r.t. output.
  2. Output common floats at  $\frac{1}{2} V+$
  3. Cable screen is not connected to device.
  4. Incorrect connection may cause irreparable damage. Contact our Sales Department if you require assistance.
  5. The transducer is factory-calibrated with an energising voltage of  $\pm 15V$  fitted with 2 metres of cable.
  6. If a cable longer than the standard 2m length is used, note that the output ripple (noise) can increase by typically 1mV p-p per metre.

## **Setting up Procedure**

1. Once the transducer is fixed in place, connect to suitable power supply and switch on.
2. To find centre position of transducer stroke (electrical null), move armature until Output 2 = 0V.
3. Move armature in/out by appropriate distance (e.g. 25mm for ACT1000) to measure negative or positive full stroke

## Specification

	Output 2	Output 1
Supply Requirements	$\pm 12V$ to $\pm 18V$ or 24V to 36V smoothed dc @ 30mA typical	$\pm 12V$ to $\pm 18V$ or 24V to 36V smoothed dc @ 30mA typical
Output Voltage	$\frac{\text{Arm.In}}{-5V}$ $\frac{\text{Null}}{0V}$ $\frac{\text{Arm.Out}}{+5V}$	$\frac{\text{Arm.In}}{0V}$ $\frac{\text{Null}}{5V}$ $\frac{\text{Arm.Out}}{10V}$
Short Circuit Proof		
Supply Voltage Rejection Ratio	1.25mV/V typical	5mV/V typical
Minimum Output Load Resistance with Supply at: 24V ( $\pm 12V$ ) 30V ( $\pm 15V$ )	} 2K }	10K 2K
Output Ripple	30mV p-p typical (Note 6)	
Output Bandwidth	200Hz Flat 350Hz – 3dB	
Output Impedance	2 ohms	
Output 1 and Output 2 Relationship	Output 1 = Output 2 + 5V ( $\pm 100mV$ )	
Linearity	0.5% of full range max. as standard, or, 0.25% and 0.1% available on some models	
Span Temp. Coefficient	$\pm 0.03\%$ FS/ $^{\circ}C$	
Operating Temperature Range	$-20^{\circ}C$ to $+70^{\circ}C$	

## Dimensions:

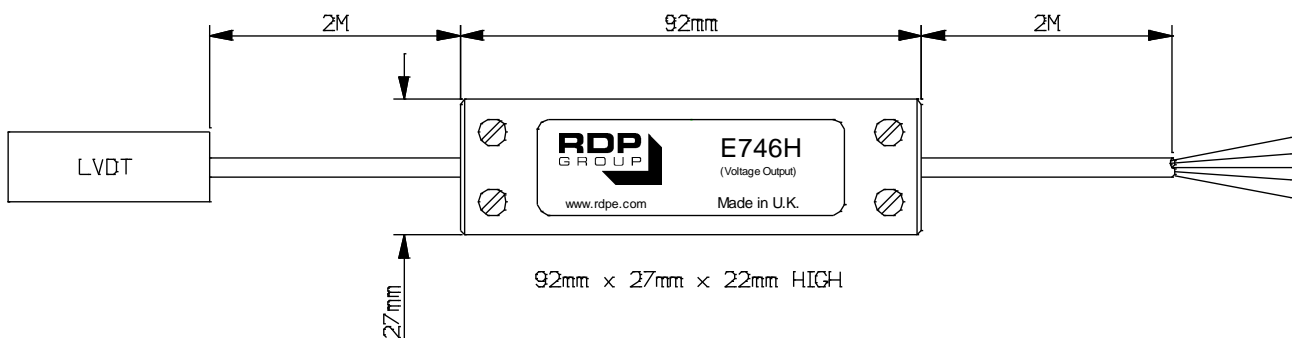

## **WARRANTY AND SERVICE**

### WARRANTY.

R.D.P. Electronics products are warranted against defects in materials or workmanship. This warranty applies for one year from the date of delivery. We will repair or replace products that prove to be defective during the warranty period provided they are returned to R.D.P. Electronics.

This warranty is in lieu of all other warranties, expressed or implied, including the implied warranty of fitness for a particular purpose to the original purchaser or to any other person. R.D.P. Electronics shall not be liable for consequential damages of any kind.

If the instrument is to be returned to R.D.P. Electronics for repair under warranty, it is essential that the type and serial number be quoted, together with full details of any fault.

### SERVICE.

We maintain comprehensive after-sales facilities and the instrument can, if necessary be returned to our factory for servicing.

Equipment returned to us for servicing, other than under warranty, must be accompanied by an official order as all repairs and investigations are subject to at least the minimum charge prevailing at the date of return.

The type and serial number of the instrument should always be quoted, together with full details of any fault and services required.

### IMPORTANT NOTES.

1. No service work should be undertaken by the customer while the unit is under warranty except with the authorisation of RDP Electronics.
2. If the instrument is to be returned to R.D.P. Electronics for repair, (including repair under warranty) it is essential that it is suitably packed and that carriage is insured and prepaid. R.D.P. Electronics can accept no liability whatsoever for damage sustained during transit.
3. It is regretted that the above warranty only covers repairs carried out at our factory. Should the instrument have been incorporated into other equipment that requires our engineers to perform the repair on site, a charge will be made for the engineer's time to and from the site, plus any expenses incurred.

The aforementioned provisions do not extend the original warranty period of any product that has been either repaired or replaced by R.D.P. Electronics.

**THIS WARRANTY MAY BE NULL AND VOID SHOULD  
THE CUSTOMER FAIL TO MEET OUR TERMS OF PAYMENT**